

DISCOVER OUR PRODUCTS AND PROJECTS ↙
soprema.com.au

FLAGON TPO ENERGY PLUS

Retrofit Waterproofing System
with SOPRASOLAR Pedestals



ABOUT SOPREMA



 **4,82**
BILLION EUROS
OF TURNOVER IN 2022

 **120+**
SUBSIDIARIES

46 TRAINING CENTRES
IN 16 COUNTRIES 

 **10,452**
EMPLOYEES
ALL OVER THE WORLD

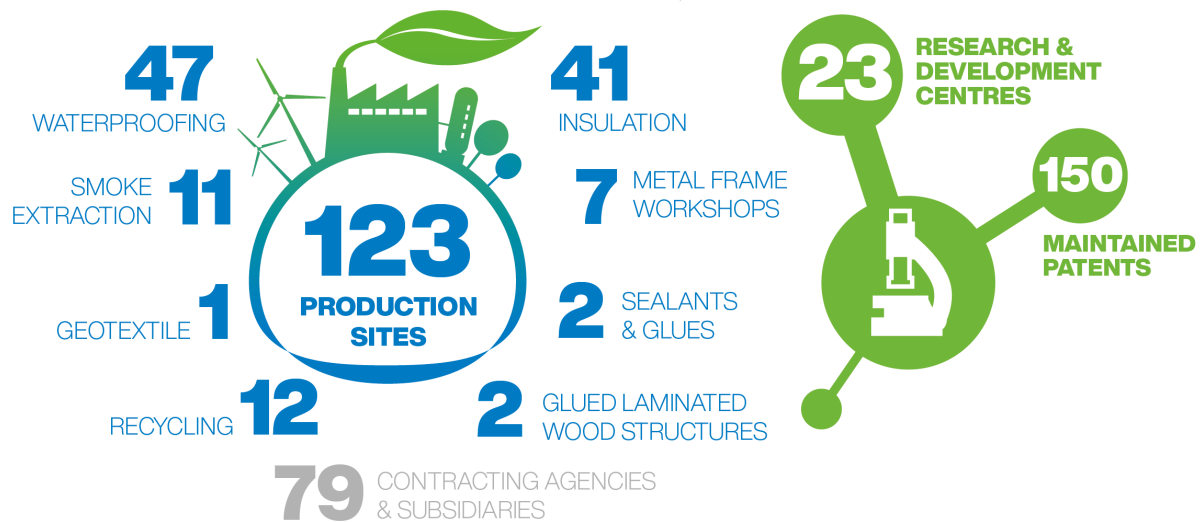

Founded in 1908 in Strasbourg, France, SOPREMA is a family-owned multinational company specialised in the production of innovative products for waterproofing, insulation, soundproofing and building vegetated solutions.

Thanks to its more than 100 years of specialisation, SOPREMA is able to offer original, high performance and high technology solutions to respond to specific challenges within the construction industry for the building envelope, underground, civil engineering, hydraulics works and swimming pool.

SOPREMA has 123 production plants with subsidiaries and distributors covering 90 countries spanning 5 continents, allowing us to constantly meet our clients' needs, wherever they may be.



Retrofit Waterproofing System with SOPRASOLAR Pedestals

SOPREMA introduces an innovative waterproofing solution designed specifically for retrofitting existing metal roof systems. Our system allows for seamless upgrades to thermal and waterproofing performance without disturbing the building owner.

Our solution involves utilising a flute fill between the metal crowns, followed by the installation of the **Sopra-ISO** PIR insulation board at the required thickness, to meet the desired R-Value. To ensure a secure attachment, we employ RhinoBond induction plates and screws based on site-specific windload calculations. Finally, we apply the **FLAGON EP/PR DE Energy Plus TPO** waterproofing membrane, which not only provides excellent waterproofing but also acts as a cool roof solution with an impressive Solar Reflectance Index (SRI) of 107. This high SRI helps regulate the building temperature, resulting in energy savings of up to 30% in air conditioning costs during hot summers.

Furthermore, by placing the insulation on the exterior of the building, our system prevents heat gain, offering additional benefits in terms of energy efficiency. We stand behind the quality of our product with a comprehensive 20-year material and workmanship warranty, and our solution boasts a life expectancy of over 35 years.

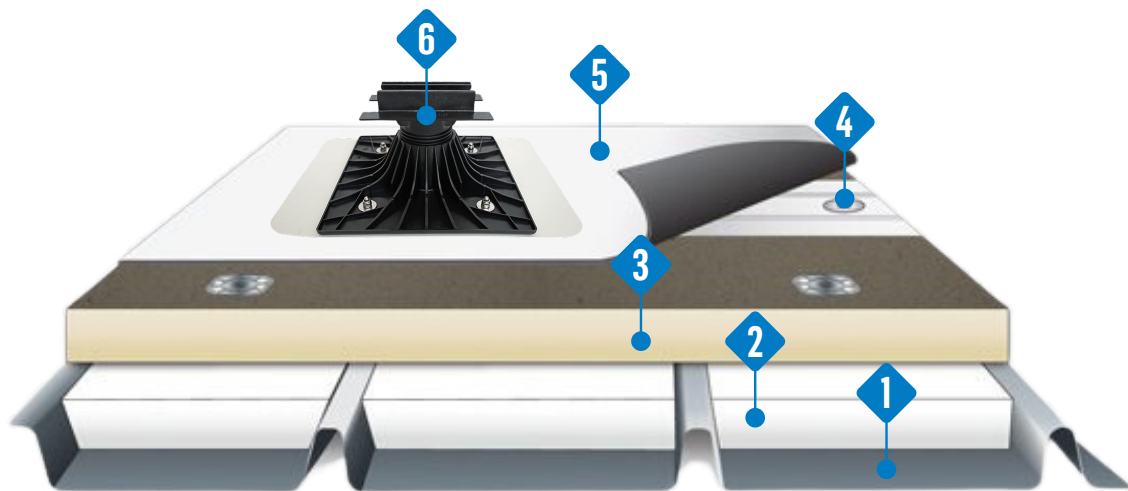

1. Metal Deck
2. Thermal Insulation Infill
3. **SOPRA-ISO BLACK**
4. Rhinobond plates
5. **FLAGON EP/PR DE Energy Plus TPO**
6. **SOPRASOLAR Pedestal**

SYSTEM BENEFITS

- **Great thermal performance**



THICKNESS	R-VALUE
50 mm	2.22
60 mm	2.66
70 mm	3.11
80 mm	3.56
90 mm	4.00
100 mm	4.44

- **Energy cost savings**
- **Sound Insulation**
- **Fire-retardant waterproofing membrane**
- **High resistance to puncture and wind stress**
- **Corrosion-free**
- **Lightweight system**
- **No exposed fixings**
- **Suitable for roof maintenance traffic**
- **No need to remove and dispose the existing metal roof**
- **Complete watertight roof system with accessories**
- **High reflective membrane surface that resists heat and UV rays with SRI of 170**

SYSTEM LAYOUT

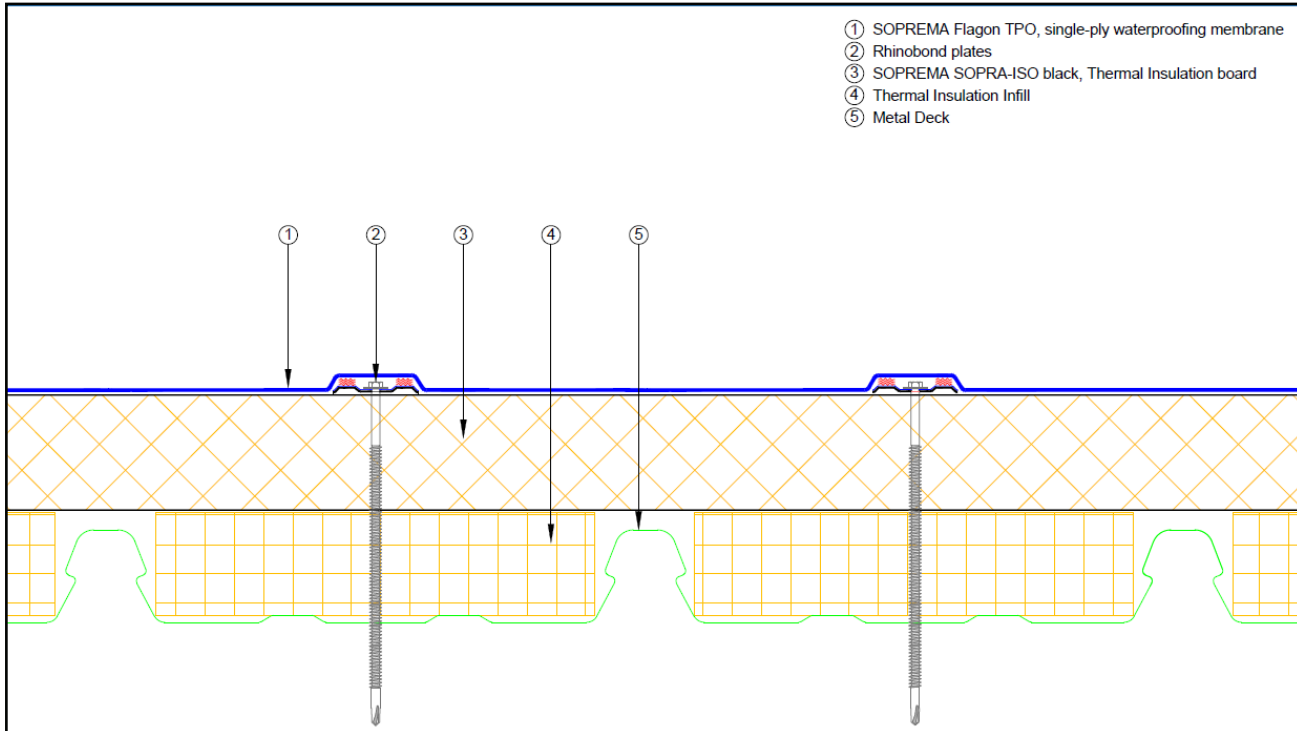

PARAPET TERMINATION

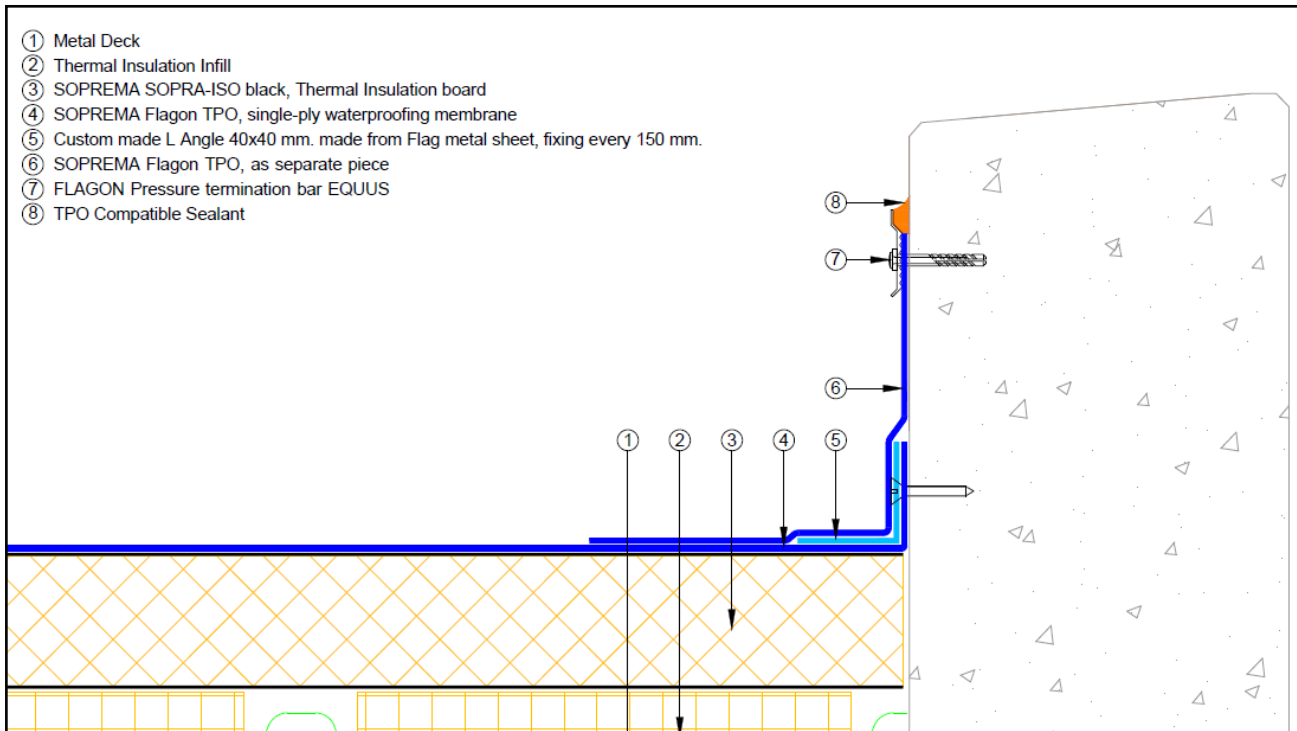

DRIP EDGE TO SPOUTING

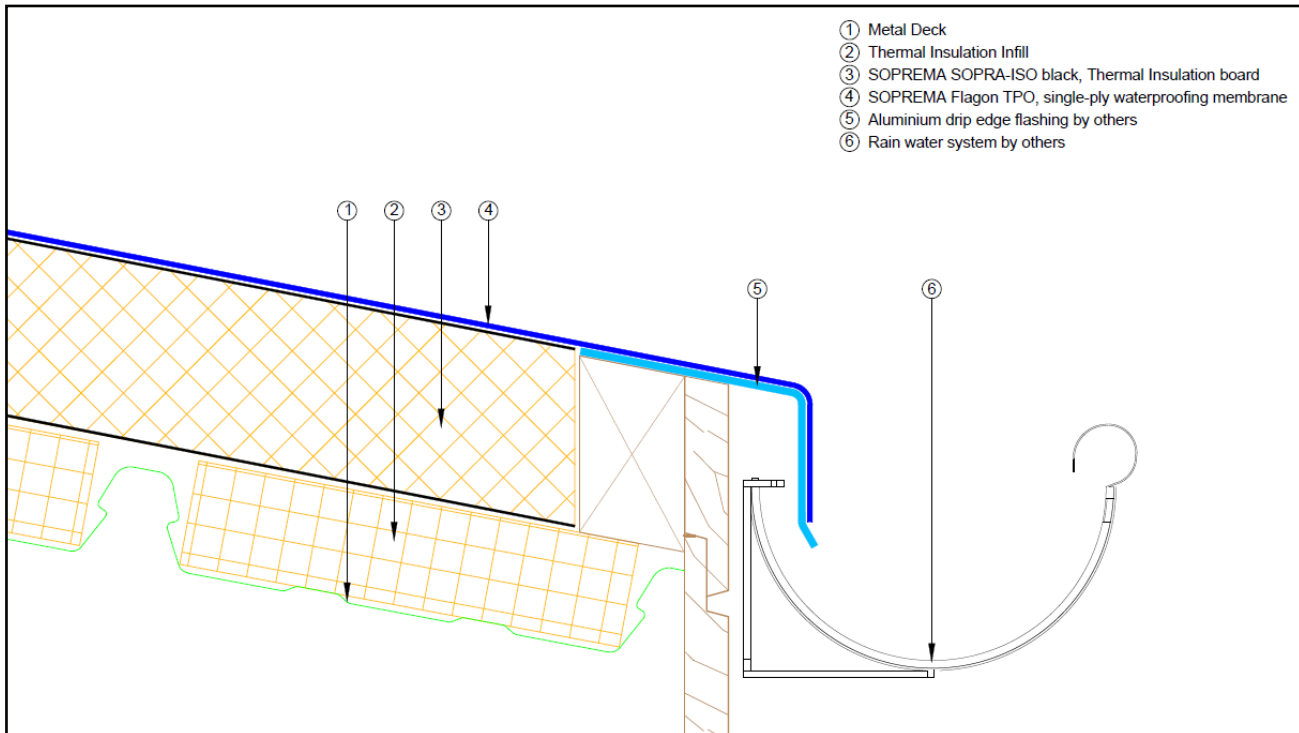

GUTTER OUTLET

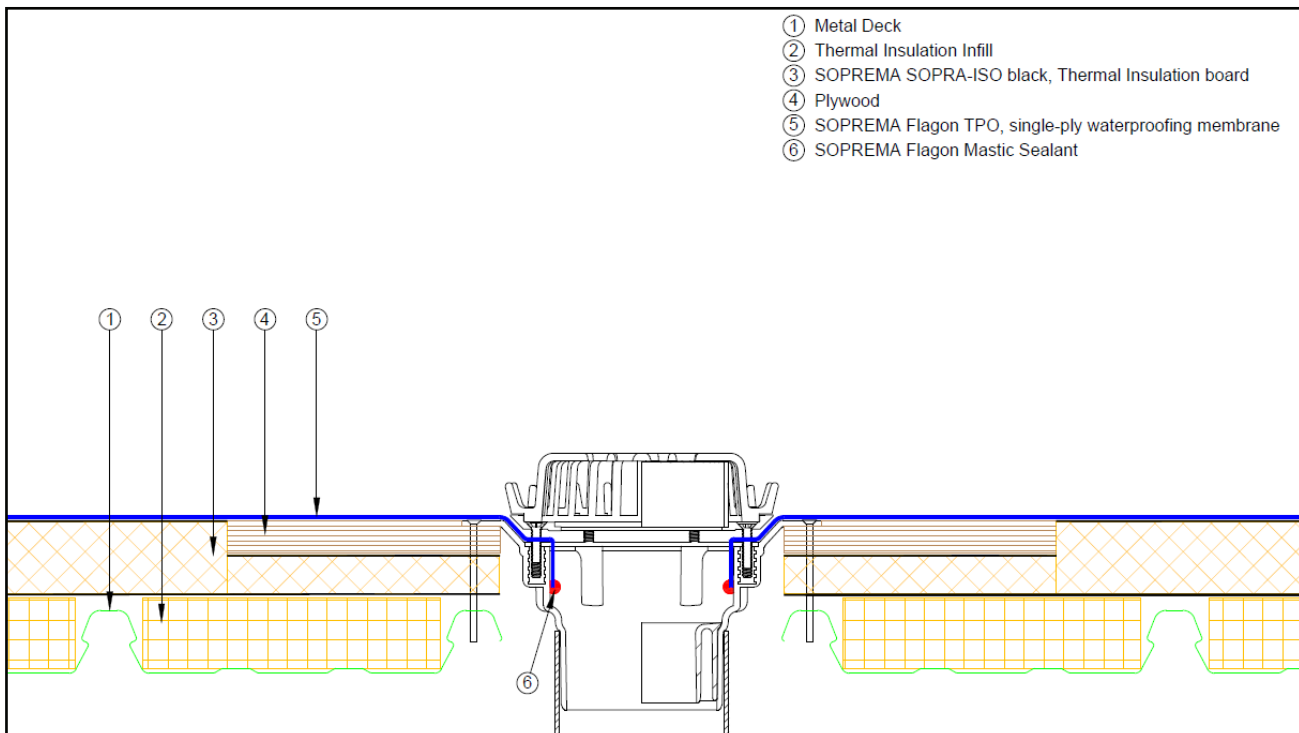

SKYLIGHT

- ① Metal Deck
- ② Thermal Insulation Infill
- ③ SOPREMA SOPRA-ISO black, Thermal Insulation board
- ④ SOPREMA Flagon TPO, single-ply waterproofing membrane
- ⑤ SOPREMA Flagon TPO, as separate piece
- ⑥ Custom made L Angle 40x40 mm. made from Flag metal sheet, fixing every 150 mm.
- ⑦ Approved TPO Adhesive
- ⑧ Skylight Joinery

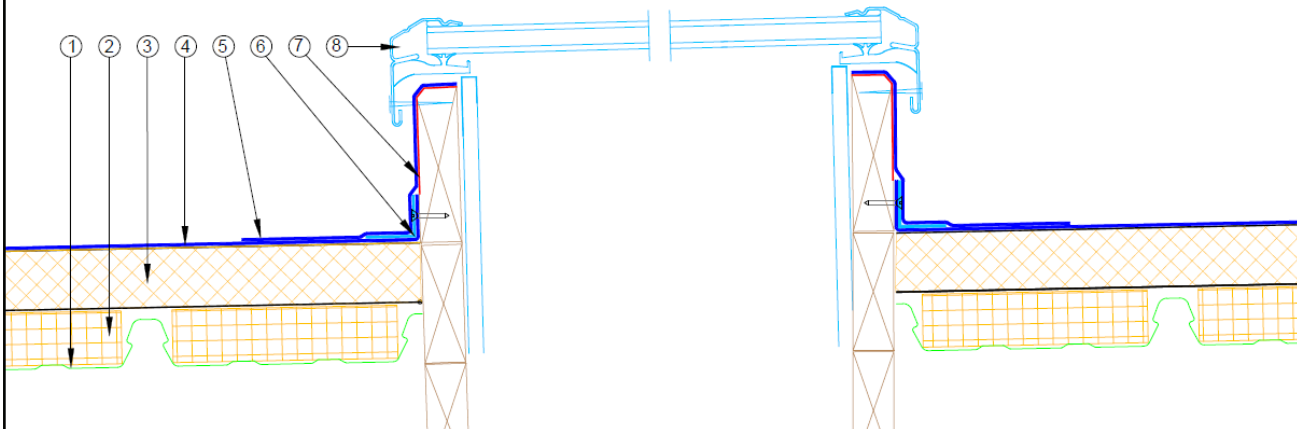

SOPRASOLAR

- ① Metal Deck
- ② Thermal Insulation Infill
- ③ SOPREMA SOPRA-ISO black, Thermal Insulation board
- ④ SOPREMA Flagon TPO, single-ply waterproofing membrane
- ⑤ SOPREMA SOPRASOLAR® FIX EVO TILT TPO

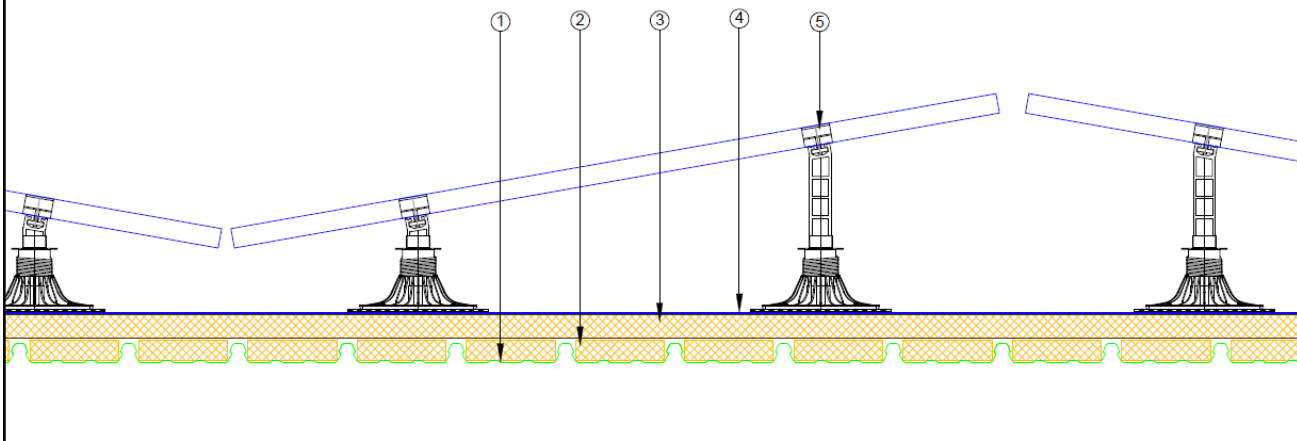

Additional details and details files available from our technical team.



EXPERTS AT YOUR SERVICE

SOPREMA has earned its place among the leaders of the waterproofing industry thanks to the expertise and availability of its technical team, supporting construction professionals in their projects from design to completion.

Local technical advice from SOPREMA include:

- Project review and advice on waterproofing solutions
- Waterproofing details review for your projects
- Waterproofing membranes and photovoltaic panel layout assistance
- Wind load calculations
- Condensation risk analysis
- Approved waterproofing contractors list
- On-site quality assurance
- CPDs and ongoing training



MAMMOTH PLATINUM WARRANTY

Coverage: Covers water infiltration caused by one or several system deficiencies from SOPREMA components or their installation

Availability: Platinum roofing contractors

Remediation: Material and labour to replace defective membrane and all other contaminated roof assembly components

Warranty period: Up to 20 years